

DO NOT OPEN THIS TEST BOOKLET UNTIL YOU ARE ASKED TO DO SO

Test Booklet Series

T. B. C. : MSP – 2/19

A

TEST BOOKLET
GENERAL STUDIES
PAPER – II

Sl. No. **221273**

Time Allowed : 2 Hours

Maximum Marks : 200

: INSTRUCTIONS TO CANDIDATES :

1. IMMEDIATELY AFTER THE COMMENCEMENT OF THE EXAMINATION, YOU SHOULD CHECK THAT THIS TEST BOOKLET DOES NOT HAVE ANY UNPRINTED OR TORN OR MISSING PAGES OR ITEMS ETC. IF SO, GET IT REPLACED BY A COMPLETE TEST BOOKLET OF THE SAME SERIES ISSUED TO YOU.
2. ENCODE CLEARLY THE TEST BOOKLET SERIES A, B, C OR D, AS THE CASE MAY BE, IN THE APPROPRIATE PLACES IN THE ANSWER SHEET USING BALL POINT PEN (BLUE OR BLACK).
3. You have to enter your **Roll No.** on the Test Booklet in the Box provided alongside. **DO NOT** write anything else on the Test Booklet.
4. YOU ARE REQUIRED TO FILL UP AND DARKEN ROLL NO., TEST BOOKLET / QUESTION BOOKLET SERIES IN THE ANSWER SHEETS AS WELL AS FILL UP TEST BOOKLET / QUESTION BOOKLET SERIES AND SERIAL NO. AND ANSWER SHEET SERIAL NO. IN THE ATTENDANCE SHEETS CAREFULLY. WRONGLY FILLED UP ANSWER SHEETS ARE LIABLE FOR REJECTION AT THE RISK OF THE CANDIDATE.
5. This Test Booklet contains 100 items (questions). Each item (question) comprises four responses (answers). You have to select the correct response (answer) which you want to mark (darken) on the Answer Sheet. In case, you feel that there is more than one correct response (answer), you should mark (darken) the response (answer) which you consider the best. In any case, choose **ONLY ONE** response (answer) for each item (question).
6. You have to mark (darken) all your responses (answers) **ONLY** on the **separate Answer Sheet** provided by using **BALL POINT PEN (BLUE OR BLACK)**. See instructions in the Answer Sheet.
7. (i) All items (questions) carry equal marks. All items (questions) are compulsory. Your total marks will depend only on the number of correct responses (answers) marked by you in the Answer Sheet.
(ii) There will be negative markings for wrong answers. 25 (twenty five) percent of marks allotted to a particular item (question) will be deducted as negative marking for every wrong response (answer).
(iii) If candidates give more than one answer, it will be treated as a wrong answer even if one of the given answers happens to be correct and there will be same penalty as above to that item (question).
8. Before you proceed to mark (darken) in the Answer Sheet the responses (answers) to various items (questions) in the Test Booklet, you have to fill in some particulars in the Answer Sheet as per the instructions sent to you with your **Admission Certificate**.
9. After you have completed filling in all your responses (answers) on the Answer Sheet and after conclusion of the examination, you should hand over to the Invigilator the **Answer Sheet** issued to you. You are allowed to take with you the candidate's copy / second page of the Answer Sheet along with the **Test Booklet**, after completion of the examination, for your reference.
10. Sheets for rough work are appended in the Test Booklet at the end.

SEAL

DO NOT OPEN THIS TEST BOOKLET UNTIL YOU ARE ASKED TO DO SO

Direction (Q. Nos. 1 to 10) : Read the following two passages and answer the questions that follow each passage. Your answer to these questions should be based on the passages only.

Passage – I

Trees are useful to man in three very important ways : they provide him with wood and other products, they give him shade, and they help to prevent drought and floods.

Unfortunately, in many parts of the world, man has not realized that the third of these services is the most important. In his eagerness to draw quick profit from the trees, he has cut them down in large numbers, only to find that with them he has lost the best friends he had.

Two thousand years ago a rich and powerful country cut down its trees to build warships, with which to gain itself an empire. It gained the empire, but without its trees, its soil became hard and poor. When the empire fell to pieces, the home country found itself faced by floods and starvation.

Even where a government realizes the importance of a plentiful supply of trees, it is difficult for it to persuade the villager to

see this. The villager wants wood to cook his food with, and he can earn money by making charcoal or selling wood to the townsman. He is usually too lazy or too careless to plant and look after new trees. So, unless the government has a good system of control, or can educate the people, the forests will slowly disappear.

This does not only mean that the villagers' sons and grandsons have fewer trees. The results are even more serious : for where there are trees their roots break the soil up — allowing the rain to sink in — and also bind the soil, thus preventing its being washed away easily, but where there are no trees, the rain falls on hard ground and flows away on the surface, causing floods and carrying away, with it the rich top-soil, in which crops grow so well. When all the top-soil is gone, nothing remains but worthless desert.

1. What is the most important role of trees in man's bio-system ?
 - (A) Trees provide us with fuel
 - (B) Trees give us fruits
 - (C) Trees provide shade
 - (D) Trees prevent drought and floods

2. What happens if trees are cut down in large numbers ?
- (A) We have more land for building houses and roads
 - (B) Soil turns hard and poor
 - (C) We get a good supply of wood
 - (D) We can build warships
3. Trees are highly useful because :
- (A) They prevent soil from being washed away
 - (B) They break the soil up
 - (C) They let the rain water sink in
 - (D) They check floods
4. Floods are harmful to agriculture because these :
- (A) Destroy trees
 - (B) Wash away the rich top soil
 - (C) Kill villagers and farmers
 - (D) Result in the break out of epidemics
5. Which one of these is not a synonym of "gain" ?
- (A) Benefit
 - (B) Advantage
 - (C) Loss
 - (D) Profit

Passage – II

To be a good teacher, you need some of the gifts of the good actor ; you must be able to hold the attention and interest of your audience ; you must be a clear speaker, with a good, strong, pleasing voice which is fully under your control ; and you must be able to act what you are teaching, in order to make its meaning clear.

Watch a good teacher, and you will see that he does not sit motionless before his class : he stands the whole time he is teaching ; he walks about, using his arms, hands and fingers to help him in his explanations, and his face to express feelings. Listen to him, and you will hear the loudness, the quality and the musical note of his voice always changing according to what he is talking about.

The fact that a good teacher has some of the gifts of a good actor does not mean that he will indeed be able to act well on the stage ; for there are very important differences between the teacher's work and the actor's. The actor has to speak words which he has learnt by heart ; he has

to repeat exactly the same words each time he plays a certain part ; even his movements and the ways in which he uses his voice are usually fixed before. What he has to do is to make all these carefully learnt words and actions seem natural on the stage.

The good teacher works in quite a different way. His audience takes an active part in his play : they ask and answer questions, they obey orders, and if they do not understand something, they say so. The teacher, therefore, has to suit his act to the needs of his audience, which is his class. He cannot learn his part by heart, but must invent it as he goes along.

I have known many teachers who were fine actors in class but were unable to take part in a stage-play because their brains would not keep discipline : they could not keep strictly to what another had written.

6. Common to a good teacher and a good actor is the quality of :
- (A) Being talkative
 - (B) Original thinking
 - (C) Capturing the attention of audience
 - (D) Making audience laugh

7. A good teacher :
- (A) is articulate
 - (B) is disciplined
 - (C) always moves in his class
 - (D) always stands in his class
8. What does a teacher not do in his class ?
- (A) He walks about in his class
 - (B) He hardly expresses his feelings
 - (C) He speaks words which he has learnt by heart
 - (D) He uses his hands and fingers while explaining
9. The audience in a class should be :
- (A) Interactive
 - (B) Passive
 - (C) Reverential
 - (D) Audacious
10. Which one of these is not a synonym of "strict" ?
- (A) Severe
 - (B) Harsh
 - (C) Stringent
 - (D) Lax

11. Interpersonal skills include the ability to _____ and manage the emotions, motivations and behaviours of oneself and others during social interactions or in a social-interactive context.
- (A) feel
 - (B) read
 - (C) write
 - (D) view
12. Many have wondered how it happens that persons with high IQs don't always _____ the top jobs : the answer often lies in interpersonal skills.
- (A) land
 - (B) leave
 - (C) sack
 - (D) seize
13. Those who have interpersonal skills are able to manage their behaviour during social interactions and align their goals to the goals of others during _____ activities.
- (A) cohesive
 - (B) collaborative
 - (C) collocation
 - (D) conservative
14. Modern teamwork often brings together individuals from diverse groups who may not share common norms, values, or _____ but who do offer unique expertise, insights, and perspectives.
- (A) accommodations
 - (B) cubicles
 - (C) salaries
 - (D) vocabularies
15. E-mail, voice mail, audio conferencing and video conferencing, and the myriad other technologies that enable individuals to communicate with each other not only increase the ways in which individuals can interact but also require a heightened sensitivity to the _____ of interpersonal interactions.
- (A) innuendos
 - (B) naivete
 - (C) nuances
 - (D) repartee

16. This idea is particularly true in the worlds of virtual learning and virtual communication, where one cannot yet use hand gestures, facial expressions, or body _____ to fully express ideas.
- (A) language
 - (B) movement
 - (C) poses
 - (D) positions
17. You have just finished typing a confidential letter from the director to the human resources office. The letter confirms that Debbie, your close friend and co-worker, has just been promoted to a new job. Debbie does not yet know of the decision. Which one of the following should you do ?
- (A) Congratulate Debbie confidentially
 - (B) Inform just a few of Debbie's close friends
 - (C) Say nothing, and wait for the official announcement
 - (D) Inform your supervisor and start planning a luncheon
18. They manage conflict effectively by devising win-win solutions, constructively influencing the behaviour of others, and using effective communication and _____ strategies.
- (A) enforcement
 - (B) evasive
 - (C) performance
 - (D) persuasive
19. Which is true about the way interpersonal relationships affect us physically ?
- (A) Deprived of interpersonal relationships, humans can become sick
 - (B) Interpersonal relationships are not actually necessary for humans ; studies show that humans raised in isolation are actually healthier than those raised with others
 - (C) Humans are the only mammals that need relationships in order to thrive
 - (D) Interpersonal relationships are necessary until about age 6, but not later in adulthood

20. The challenge is to _____ interpersonal skills not only in face-to-face interactions but in virtual interactions as well.
- (A) perfect
(B) perform
(C) produce
(D) project
21. Message is any signal that triggers the response of a _____.
- (A) receiver
(B) driver
(C) sender
(D) cleaner
22. Oral communication is the interchange of _____ between the sender and receiver.
- (A) verbal messages
(B) cues and clues
(C) signs and gestures
(D) written messages
23. _____ context refers to the relationship between the sender and receiver.
- (A) Social
(B) Physical
(C) Cultural
(D) Chronological
24. _____ refers to all these factors that disrupt the communication.
- (A) Nonsense
(B) Noise
(C) Nowhere
(D) Nobody
25. (I) All the trees in the park are flowering trees.
(II) Some of the trees in the park are dogwoods.
(III) All dogwoods in the park are flowering trees.
- If the first two statements are true, the third statement is :
- (A) True
(B) False
(C) Uncertain
(D) Can't say
26. Of the following two statements, both of which cannot be true, but both can also be false. Which are these two statements ?
- (I) All machines make noise.
(II) Some machines are noisy.
(III) No machine makes noise.
(IV) Some machines are not noisy.
- (A) I and II
(B) III and IV
(C) I and III
(D) II and IV

27. Circle indicates 'strong', square indicates 'tall' and triangle indicates 'army officers'. The strong army officers who are not tall is shown by :

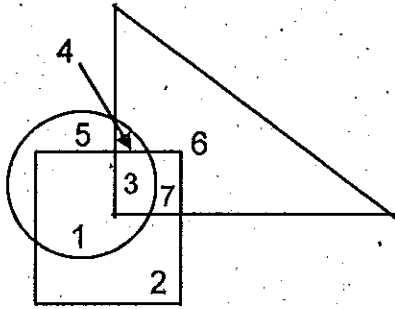

- (A) 4
- (B) 3
- (C) 5
- (D) 6

28. In a family there are husband, wife, two sons and two daughters. All the ladies were invited to a dinner. Both sons went out to play. Husband did not return from office. Who was at home ?

- (A) Only wife was at home
- (B) All ladies were at home
- (C) Only sons were at home
- (D) No body was at home

29. Which of the following figures best depicts the relationship among Criminals, Thieves and Judges ?

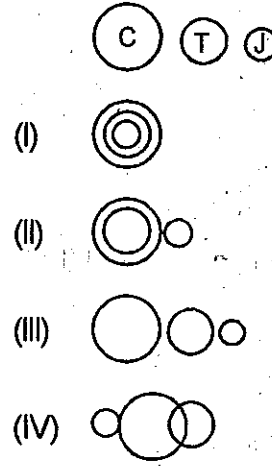

- (A) I
- (B) II
- (C) III
- (D) IV

30. There are five books A, B, C, D and E placed on a table. If A is placed below E, C is placed above D, B is placed below A and D is placed above E, then which of the following books touches the surface of the table ?

- (A) C
- (B) B
- (C) A
- (D) E

31. (I) Artists are generally whimsical.
 (II) Some of them are frustrated.
 (III) Frustrated people are prone to be drug addicts.

Based on these statements which of the following conclusions is true ?

- (A) All frustrated people are drug addicts
 (B) Some artists may be drug addicts
 (C) All drug addicts are artists
 (D) Frustrated people are whimsical

32. If A is the son of Q, Q and Y are the sisters, Z is the mother of Y, P is the son of Z, then which of the following statements is correct ?

- (A) P is the maternal uncle of A
 (B) P and Y are sisters
 (C) A and P are cousins
 (D) None of these

33. Three ladies X, Y and Z marry three men A, B and C. X is married to A, Y is not married to an engineer, Z is

not married to a doctor, C is not a doctor and A is a lawyer. Then which of the following statements is correct ?

- (A) Y is married to C who is an engineer
 (B) Z is married to C who is a doctor
 (C) X is married to a doctor
 (D) None of these

34. Find the number of triangles in the given figure :

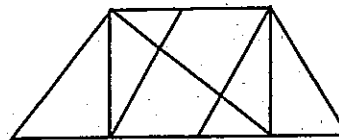

- (A) 8
 (B) 10
 (C) 12
 (D) 14

35. Pointing to a photograph, a man said, "I have no brother or sister but that man's father is my father's son". Whose photograph was it ?

- (A) His own
 (B) His nephew's
 (C) His father's
 (D) His son's

36. Find the minimum number of straight lines required to make the given figure :

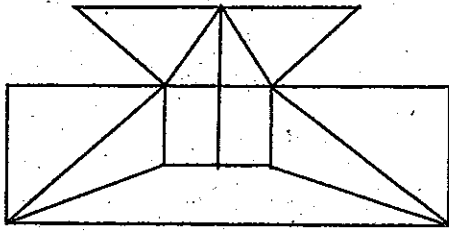

- (A) 16
 (B) 17
 (C) 18
 (D) 19
37. Find the number of triangles in the given figure :

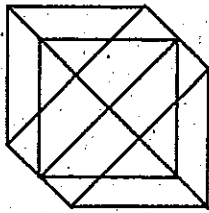

- (A) 18
 (B) 20
 (C) 24
 (D) 27
38. A, B, C, D, E and F are the members of a club. There are two married couples in the group. A is the brother of D's husband. C is the President of Women's Association. F is a Sitar Player and Bachelor. B's

wife is not a member of the club. Four of them belong to the same family. B and F are colleagues in the club. How is F related to B ?

- (A) Wife
 (B) Husband
 (C) Father
 (D) It is not possible to determine
39. A family consists of six members P, Q, R, X, Y and Z. Q is the son of R but R is not the mother of Q. P and R are a married couple. Y is the brother of R. X is the daughter of P. Z is the brother of P. How many children does P have ?

- (A) 1
 (B) 2
 (C) 3
 (D) 4
40. Solve the problem and indicate the best of the answer choices given :
 If $u > t$, $r > q$, $s > t$ and $t > r$, which of the following must be true ?

- (I) $u > s$
 (II) $s > q$
 (III) $u > r$
- (A) I only
 (B) II only
 (C) III only
 (D) II and III

41. _____ is the final step in the decision making process.
- (A) Implementing the decision
 - (B) Evaluating the decision
 - (C) Recognizing the decision
 - (D) Evaluating the alternatives
42. _____ is not one of the eight steps in the decision making process.
- (A) Identifying the problem
 - (B) Analyzing alternative solutions
 - (C) Implementing the decision
 - (D) Delegating the decision making
43. Ivan spoke out in a meeting in favour of a potential cost savings that would result from a new employee benefits program offered by the company. He later received information that showed that his initial decision about the cost savings was incorrect, but he was too embarrassed to publicly admit he was wrong, so he is sticking by his original statement. Ivan is experiencing :
- (A) Bounded rationality
 - (B) Satisfying
 - (C) Escalation of commitment
 - (D) Poor use of rational making process
44. _____ is one of the disadvantages of group decisions that typically results in groups that are very cohesive.
- (A) Conflict
 - (B) Groupthink
 - (C) Domination
 - (D) Compromise
45. "Decision making under risk" means _____.
- (A) the decision has no data on which to base his or her decision
 - (B) the decision maker is used to dealing with high-risk situations
 - (C) the decision maker knows all of the risks involved in the situation
 - (D) the decision maker can estimate the risk involved in making a decision
46. The first step in the decision making process is which of the following ?
- (A) Develop the alternatives
 - (B) Analyze alternatives
 - (C) Identify decision criteria
 - (D) Identify the problem

47. The strengths and weaknesses of each alternative become obvious in which step of the decision making process ?

- (A) Identify the problem
- (B) Identify the decision criteria
- (C) Analyze the alternatives
- (D) Implement the alternative

48. Joe, the manager of Internet Made Easy, is concerned. He is trying, like all technological based companies, to stay ahead of the competition by being the first to offer the new services available on the internet. His business offers training to local businesses and so he must offer the latest available information ; however, he must also advertise the classes and the content, which means going to the publisher with that information six weeks before a class is to begin.

What should his next series of classes offer ? Joe is operating under which of the following conditions ?

- (A) Uncertainty
- (B) Certainty
- (C) Risk
- (D) Optimal decision making

49. Look at this series below :

2, 1, (1/2), (1/4), _____

What number should come next ?

- (A) (1/3)
- (B) (1/8)

(C) (2/8)

(D) (1/16)

50. (I) Tanya is older than Eric.

(II) Cliff is older than Tanya.

(III) Eric is older than Cliff.

If the first two statements are true, the third statement is :

(A) True

(B) False

(C) Uncertain

(D) Cannot be determined

51. Statements :

(I) The prices of petrol and diesel in the domestic market have remained unchanged for the past few months.

(II) The crude oil prices in the international market have gone up substantially in the last few months.

(A) Statement I is the cause and statement II is its effect

(B) Statement II is the cause and statement I is its effect

(C) Both the statements I and II are independent causes

(D) Both the statements I and II are the effects of independent causes

52. **Statement :** In a one day cricket match, the total runs made by a team were 200. Out of these, 160 runs were made by the spinners.

Conclusions :

(I) 80% of the team consists of spinners.

(II) The opening batsmen were spinners.

(A) Only conclusion I follows

(B) Only conclusion II follows

(C) Either I or II follows

(D) Neither I nor II follows

53. Look at this series below :

8, 6, 9, 23, 87, _____

What number should come next ?

(A) 128

(B) 226

(C) 324

(D) 429

54. **Statements :**

(I) The Reserve Bank of India has recently put restrictions on few small banks in the country.

(II) The small banks in the private and co-operative sector in India are not in a position to withstand the competitions of the bigger in the public sector.

(A) Statement I is the cause and statement II is its effect

(B) Statement II is the cause and statement I is its effect

(C) Both the statements I and II are independent causes

(D) Both the statements I and II are the effects of independent causes

55. A candidate attempted 12 questions and secured full marks in all of them. If he obtained 60% in the test and all questions carried equal marks, then what number of questions in the test ?

(A) 36

(B) 30

(C) 25

(D) 20

56. Which word does NOT belong with the others ?

(A) Inch

(B) Ounce

(C) Centimeter

(D) Yard

57. Here are some words translated from an artificial language :

gorblflur means fan belt.

pixngorbl means ceiling fan.

arthtusl means tile roof.

Which word could mean "ceiling tile" ?

(A) Gorbtlusl

(B) Flurgorbl

(C) Arthflur

(D) Pixnarth

58. Odometer is to mileage as compass is to :

- (A) Speed
- (B) Hiking
- (C) Needle
- (D) Direction

59. $45 + 46 + 47 + \dots + 113 + 114 + 115 = ?$

- (A) 5600
- (B) 5656
- (C) 5680
- (D) 4000

60. L. C. M. of $\frac{2}{3}, \frac{4}{9}, \frac{5}{6}, \frac{7}{12}$ is :

- (A) $\frac{1}{18}$
- (B) $\frac{1}{36}$
- (C) $\frac{35}{9}$
- (D) $\frac{140}{3}$

61. $8^{0.28} \times 4^{0.08} = ?$

- (A) $8^{0.36}$
- (B) $4^{0.36}$
- (C) 2
- (D) 1

62. If the sum of a few numbers is 450 and their mean is 50 and if another number 100 is included, the mean would become :

- (A) 55
- (B) 60
- (C) 75
- (D) 150

63. In a two digit number, the digit in the unit place is 2 more than three times the digit in the tens place. If the sum of digits is 6, the number is :

- (A) 15
- (B) 24
- (C) 42
- (D) 51

64. Five years ago, Vinay's age was one-third of the age of Vikas and now Vinay's age is 17 years. What is the present age of Vikas ?

- (A) 9 years
- (B) 36 years
- (C) 41 years
- (D) 51 years

$$65. \frac{1}{1+x^{(b-a)}+x^{(c-a)}} + \frac{1}{1+x^{(a-b)}+x^{(c-b)}} + \frac{1}{1+x^{(b-c)}+x^{(a-c)}} = ?$$

- (A) 0
 (B) 1
 (C) x^{a-b-c}
 (D) x^{a+b+c}

66. 3 litres of water is added to 15 litres of a mixture of a 20% solution of alcohol in water. The strength of alcohol is now :

- (A) $12\frac{1}{2}\%$
 (B) $16\frac{2}{3}\%$
 (C) 24%
 (D) 16%

67. A sofa set carrying a sale price ticket of Rs. 5,000 is sold at a discount of 4% thereby gaining 20%. The trader's cost price of the sofa set is :

- (A) Rs. 3,600
 (B) Rs. 3,800
 (C) Rs. 4,000
 (D) Rs. 4,200

68. 8 men can finish a piece of work in 40 days. If 2 more men join with them, then the work will be completed in :

- (A) 30 days
 (B) 32 days

- (C) 36 days
 (D) 25 days

69. Kamal can do a work in 15 days. Bimal is 50% more efficient than Kamal. The number of days, Bimal will take to do the same piece of work, is :

- (A) 10
 (B) $10\frac{1}{2}$
 (C) 12
 (D) 14

70. Two pipes can fill a tank in 20 minutes and 30 minutes respectively. If both pipes are opened simultaneously, then the tank will be filled in :

- (A) 10 minutes
 (B) 12 minutes
 (C) 15 minutes
 (D) 25 minutes

71. A person starting from his house covers a distance at 15 km/hr and returns to the starting place at 10 km/hr. His average speed during the whole journey is :

- (A) 11 km/hr
 (B) 12 km/hr
 (C) $12\frac{1}{2}$ km/hr
 (D) 13 km/hr

72. A merchant has 1,000 kg of sugar, part of which he sells at 8% profit and rest at 18% profit. He gains 14% on the whole. The quantity sold at 8% profit is :

- (A) 400 kg
- (B) 560 kg
- (C) 600 kg
- (D) 640 kg

73. A sum of Rs. 10,000 is lent partly at 8% and the remaining at 10% per annum. If the yearly interest on the average is 9.2%, the money lent at 10% is :

- (A) Rs. 6,000
- (B) Rs. 5,500
- (C) Rs. 5,000
- (D) Rs. 4,500

Direction (Q. Nos. 74 to 78) : Study the following table carefully and answer the given questions. The number of candidates appeared, passed and selected in a competitive examination from four states over the years.

State	A			B			C			D		
	A	P	S	A	P	S	A	P	S	A	P	S
2001	850	215	25	1050	245	35	990	195	28	1080	300	36
2002	880	240	20	980	230	30	650	150	28	1150	320	38
2003	750	180	22	1120	210	28	840	180	25	995	280	42
2004	920	290	36	890	190	32	780	160	32	975	260	39
2005	960	300	32	950	225	40	1020	220	36	888	240	32
2006	820	250	28	1180	200	38	930	215	35	864	216	30

A = Appeared, P = Passed, S = Selected

74. In the year 2001, which state had the lowest percentage of candidates selected over the candidates appeared ?

- (A) A
- (B) B
- (C) C
- (D) D

75. During which of the following years, the passing percentage over appeared is the highest from state 'D' ?

- (A) 2001
- (B) 2006
- (C) 2004
- (D) 2003

76. Total number of candidates selected from state 'A' is approximately what percentage of the total number of candidates selected from state 'B' ?

- (A) 88
- (B) 85
- (C) 75
- (D) 80

77. During which of the following years, the percentage of candidates selected over passed is the lowest for state 'B' ?

- (A) 2001
- (B) 2002
- (C) 2004
- (D) 2005

78. What is the ratio between number of candidates passed from state 'A' in 2002 to that from state 'D' in 2005 ?

- (A) 1 : 1
- (B) 1 : 2
- (C) 2 : 1
- (D) 2 : 3

Direction (Q. Nos. 79 to 83) : Study the following graph carefully and answer the given questions.

Percent profit earned by two companies A and B over the years 2001 to 2007.

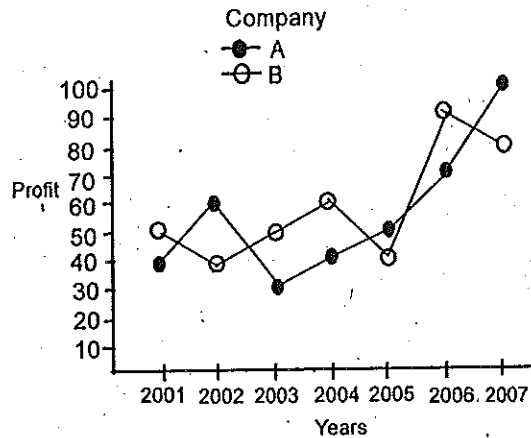

79. Investment of company 'B' in 2007 is more by 40% than that in the previous year. Income in 2007 was what percent of the investment in 2006 ?

- (A) 280%
- (B) 252%
- (C) 242%
- (D) 52%

80. Investment of company 'B' in 2003 was Rs. 15,40,000. What was its income in that year ?

- (A) Rs. 23.33 lakhs
- (B) Rs. 22.33 lakhs
- (C) Rs. 22.23 lakhs
- (D) Rs. 23.23 lakhs

81. Income of company 'A' in 2005 was Rs. 21.7 lakhs. What was the investment ?

- (A) Rs. 14.6 lakhs
- (B) Rs. 41.60 lakhs
- (C) Rs. 50.26 lakhs
- (D) None of these

82. Average investment of company 'A' over the years was Rs. 26 lakhs. What was its average income over the years ?

- (A) Rs. 40.56 lakhs
- (B) Rs. 50.26 lakhs
- (C) Data inadequate
- (D) Rs. 41.56 lakhs

83. Income of company 'A' in 2005 is equal to the investment of company B in 2006. What is the ratio of the investment of company 'A' in 2005 to the investment of company 'B' in 1996 ?

- (A) 37 : 36
- (B) 30 : 26
- (C) 20 : 31
- (D) None of these

Direction (Q. Nos. 84 to 88) : The pie charts given show the data on number of foreign collaborations approved with various countries. Study the pie charts and answer the given questions.

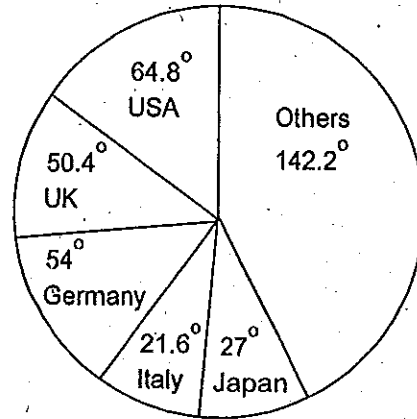

1998 : Total = 1200

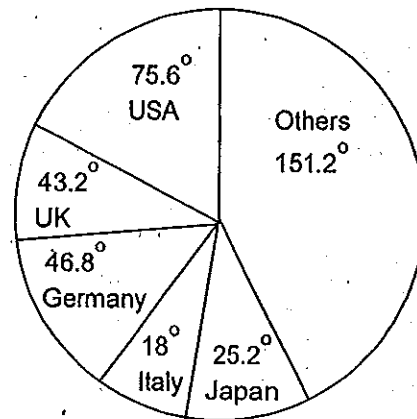

1999 : Total = 1500

84. By what percentage did the foreign collaborations approved with Germany change in 1999 with respect to 1998 ?

- (A) 2% increase
- (B) 2% decrease
- (C) $8\frac{1}{3}\%$ increase
- (D) $8\frac{1}{3}\%$ decrease

85. What is the ratio of the number of foreign collaborations approved with USA in 1988 to those in 1999 ?

- (A) 4 : 5
- (B) 12 : 27
- (C) 15 : 28
- (D) 24 : 35

86. What is the difference in percentage share of UK in the foreign collaborations approved in 1998 and 1999 ?

- (A) 1.5%
- (B) 2.0%
- (C) 2.5%
- (D) 3.0%

87. By how much did the number of foreign collaborations approved with Italy increase from 1998 to 1999 ?

- (A) 30
- (B) 10
- (C) 3
- (D) Zero

88. In 1999 USA accounts for what percent of total foreign collaborations approved ?

- (A) 21%
- (B) 22%
- (C) 23%
- (D) 24%

Direction (Q. Nos. 89 & 90) : The table given below shows the production of five types of cars by a company in the year 2001 to 2006. Study the table and answer the questions.

Production of cars in ('000) by a company

Year → Type ↓	2001	2002	2003	2004	2005	2006	Total
P	8	20	16	17	21	6	88
Q	16	10	14	12	12	14	78
R	21	17	16	15	13	8	90
S	4	6	10	16	20	31	87
T	25	18	19	30	14	27	133
Total	74	71	75	90	80	86	476

89. The percent increased in total production of all types of cars in 2004 to that in 2003 was :

- (A) 15
- (B) 20
- (C) 25
- (D) 30

90. The production of which types of cars was 25% of the total production of all types of cars during 2005 ?

- (A) S
- (B) R
- (C) P
- (D) Q

Direction (Q. Nos. 91 to 100) : Read the following two passages and answer the questions that follow each passage. Your answer to these questions should be based on the passages only.

Passage – I

Suppose I say to you in English that "I spent yesterday evening with a neighbour". You may well wonder whether my companion was male or female, but I have the right to tell you politely that it's none of your business. But if we were speaking French or German, I wouldn't have the privilege to equivocate in this way, because the grammar of these languages compels me to inform you about the sex of my companion whether or not I feel it is remotely your concern. This does not mean, of course, that English speakers are unable to understand the differences between evenings spent with male or female neighbours, but it does mean that they do not have to consider the sexes of neighbours, friends, teachers and a host of other persons each time they come up in a conversation, whereas speakers of some languages are obliged to do so.

On the other hand, English does oblige you to specify certain types of information that can be left to the context in other languages. If I want to tell you in English about a dinner with my neighbour, I may not have to mention the neighbour's sex, but I do have to tell you something about the timing of the event. I have to decide whether we dined, have been

dining, are dining, will be dining and so on. Chinese, on the other hand, does not oblige its speakers to specify the exact time of the action in this way, because the same verb form can be used for past, present or future actions. Again, this does not mean that the Chinese are unable to understand the concept of time. But it does mean they are not obliged to think about timing whenever they describe an action.

When your language routinely obliges you to specify certain types of information, it forces you to be attentive to certain details in the world and to certain aspects of experience that speakers of other languages may not be required to think about all the time. And since such habits of speech are cultivated from the earliest age, it is only natural that they can settle into habits of mind that go beyond language itself, affecting your experiences, perceptions, associations, feelings, memories and orientation in the world.

91. "I have the right to tell you politely that it's none of your business." What is "none of your business" ?
- (A) My spending or not spending an evening with my neighbour
 - (B) Your wondering whether my neighbour is male or female
 - (C) Wondering whether it is my right or not to tell you politely that it's none of our business
 - (D) Your wanting to know whether my neighbour was male or female

92. What determines the gender-marker of the words we use in a language ?

- (A) Linguistics
- (B) Morphology
- (C) Syntax
- (D) Grammar

93. Which of the following statements about Chinese and English is true according to this passage ?

- (A) Chinese is indifferent unlike English to events in time.
- (B) Chinese cannot distinguish between the English tenses.
- (C) Chinese words for action do not reflect the tenses the way those of English do.
- (D) Chinese words cannot understand the sense of time the way English words do.

94. When you refer to the people of China you say _____ and when you refer to the people of England you say _____.

- (A) The Chinese, The English
- (B) Chinese, English
- (C) The Chinese, English
- (D) Chinese, The English

95. "When your language *routinely* obliges you to specify certain types of information". What does the italicized word mean ?

- (A) As done sometimes out of compulsion
- (B) As done always out of compulsion
- (C) As done regularly as procedure
- (D) As done by default, not otherwise

Passage – II

Scientists are primarily moved by curiosity, by the passionate desire to know how things happen in life and nature and secondly, by the desire to use this knowledge for human welfare. Nobody can deny that science has rendered invaluable service to mankind in various spheres. It is due to the discoveries of science that we have been able to find a cure for most diseases and prevent the outbreak of epidemics, thereby vastly increasing life expectancy.

The most valuable service which science has rendered to mankind is that it has given it supreme self confidence. It has given man the assurance that, instead of being a slave to his environment, he can control and modify it to suit his needs. Before the scientific era, an agriculturalist eked out a precarious existence, his livelihood depending upon the vagaries of

the weather. Insect pests, locusts, drought devastated his fields. Now we have built huge dams to supply waters through perennial canals, manufactured fertilizers which enormously increase agricultural production, produced effective pesticides, learnt how to prevent soil erosion, introduced multiple cropping and devised other ways to improve output.

Population control would still be needed if food production is to keep pace with the growth in numbers, but the spectacular progress which scientific cultivation has made possible in the field of agriculture has belied all Malthusian fears. Progress in the industrial field has been even more spectacular, thanks to the application of science to industry. The world, particularly the developed part of it, now enjoys a standard of living which in former ages was not even enjoyed by the wealthier classes. The higher standards of living have made it possible for the governments to provide the social services on a liberal scale.

The machine has not only relieved man of heavy burdensome tasks, but has also provided him with ample leisure in which he can engage himself in cultural pursuits, cultivate various kinds of hobbies and travel. It is through science that he has

been able to invent new sources of entertainment and education, such as cinema, radio and television. The enormous popularity of these sources of entertainment proves how useful they are to mankind. Before the invention of the printing press, education was confined to a small section of the community and was of a predominantly religious character. The printing press revolutionised the art of publication and brought books, periodicals and newspapers within everyone's reach.

96. What made the discoveries of science possible ?
- (A) Inquiry
 - (B) Reasoning
 - (C) Curiosity
 - (D) Skill
97. What significant change in man's life resulted with his knowledge of science ?
- (A) It has made him bold and creative
 - (B) It has made of him a master of his environment
 - (C) It has made him cautious about his environment
 - (D) It has made little difference to his life

98. In which part of the world do people enjoy a higher standard of living ?
- (A) The West
 - (B) The developed
 - (C) The Mid-Eastern
 - (D) The underdeveloped
99. Who would be responsible for extending social services ?
- (A) Governments
 - (B) Local-self governments
 - (C) Scientific institutions
 - (D) Wealthier classes
100. What are enormously popular among the sources of entertainment ?
- (A) Cinema, radio, television
 - (B) Books, periodicals, newspapers
 - (C) Various kinds of hobbies and travel
 - (D) Science, culture, education

